



Vestax
Professional Single CD Player
CDX-05
OWNER'S MANUAL

NOTE

- ① The CDX-05 cannot read CD-R/RW discs that are not finalized.
- ② The CDX-05 can convert tracks to CD-DA and MP3 formats.
If the CD has been made on a computer, it can only read MP3 and CD-DA formats.
CD-DA format tracks will be given priority to play when both CD-DA and MP3 data is recorded in the disc, MP3 tracks will not be played.

※There are features that are not supported when playing MP3 tracks. Read P.20 [MP3 file playback] for further instructions.
- ③ The CDX-05 cannot guarantee stable operation when playing a [COPY GUARD CD] or other CDs that do not conform to the standard level. For details of standard CDs, please ask the producer of the CD.



VESTAX CORPORATION
1-18-6 Wakabayashi, Tokyo 154-0023 Japan
Phone:03-3412-7011 Fax:03-3412-7013

VESTAX (Europe)Ltd.
Unit 5 Riverwey Industrial Park Alton, Hampshire GU34 2QL England
Phone:44-1420-83000 Fax:44-1420-80040

CONGRATULATIONS!

Thank you for purchasing the VESTAX CDX-05, Professional Single CD player.
Please read this owner's manual carefully before you start to use your mixer in order to fully understand all of the special features.

CONTENTS	
CAUTION	2
IMPORTANT SAFEGUARDS	4
FEATURES	5
BEFORE USE	6
1 . Functions and Controls	7
2 . Play back operation	11
3 . More advanced operation	15
4 . Specifications	24

	CAUTION	
RISK OF ELECTRIC SHOCK DO NOT OPEN		
CAUTION : TO REDUCE THE RISK OF ELECTRIC SHOCK DO NOT REMOVE COVER (OR BACK) NO USER-SERVICEABLE PARTS INSIDE REFER SERVICING TO QUALIFIED SERVICE PERSONNEL		



The lightning flash with arrowhead symbol, within an equilateral triangle, is intended to alert the user to the presence of uninsulated "dangerous voltage" within the product's enclosure that may be of sufficient magnitude to constitute a risk of electric shock to persons.



The exclamation point within an equilateral triangle is intended to alert the user to the presence of important operating and maintenance (servicing) instructions in the literature accompanying the appliance.

TO REDUCE THE RISK OF FIRE OR ELECTRIC SHOCK, DO NOT EXPOSE THIS APPLIANCE TO RAIN OR MOISTURE.

CAUTION : TO PREVENT ELECTRIC SHOCK, MATCH BLADE OF PLUG TO WIDE SLOT, FULLY INSERT

ATTENTION : POUR EVITER LES CHOCS ELECTRIQUES, INTRODUIRE LA LAME LA PLUS LARGE DE LA FICHE DANS LA BORNE CORRESPONDANTE DE LA PRISE ET POUSSER JUSQU' AU FOND

NOTE

This equipment has been tested and found to comply with the limits for a Class B digital device, pursuant to Part 15 of the FCC Rules. These limits are designed to provide reasonable protection against harmful interference in a residential installation. This equipment generates, uses and can radiate radio frequency energy and, if not installed and used in accordance with the Instructions, may cause harmful interference to radio communications. However, there is no guarantee that interference will not occur in a particular installation. If this equipment does cause harmful interference to radio or television reception, which can be determined by turning the equipment off and on, the user is encouraged to try to correct the interference by one or more of the following measures.

- Reorient or relocate the receiving antenna.
- Increase the separation between the equipment and receiver.
- Connect the equipment into an outlet on a circuit different from that to which the receiver is connected.
- Consult the dealer or an experienced radio/TV technician for help.

NOTE

Changes or modifications may cause this unit to fail to comply with Part 15 of the FCC Rules and may void the user's authority to operate the equipment.

This Class B digital apparatus meets all requirements of the Canadian Interference-Causing Equipment Regulations.

Cet appareil numérique de la Classe B respecte toutes les exigences du Règlement sur le matériel brouilleur du Canada.

IMPORTANT

This apparatus is fitted with an approved moulded 13 Amp plug. To change a fuse in this type of plug proceed as follows:

1. Remove fuse cover and fuse.
2. Fix new fuse which should be a BS1362 5A. A.S.T.A. or BSI approved type.
3. Refit the fuse cover.

If the fitted plug is not suitable for your socket outlets, it should be cut off and an appropriate plug fitted in its place. If the mains plug contains a fuse, this should have a value of 5A. If a plug without a fuse is used, the fuse at the distribution board should not be greater than 5A.

NOTE

The severed plug must be destroyed to avoid a possible shock hazard it be inserted into a 13A socket elsewhere.

CLASS 1 LASER PRODUCT
LUOKAN 1 LASERLAITE KLASI 1
LASERAPPARAT

HOW TO CONNECT A PLUG

The wires in the mains lead are coloured in accordance with the following code:

BLUE-"NEUTRAL"("N")

BROWN-"LIVE"("L")

1. The BLUE wire must be connected to the terminal which is marked with the letter "N" or coloured BLACK.
2. The BROWN wire must be connected to the terminal which is marked with the letter "L" or coloured RED.
3. Do not connect either wires to the earth terminal in the plug which is marked by the letter "E" or by the safety earth symbol ↓ or coloured green or green-and-yellow.

Before replacing the plug cover, make certain that the cord grip is clamped over the sheath of the lead-not simply over the two wires.

IMPORTANT SAFEGUARDS

READ BEFORE OPERATING EQUIPMENT

This product was designed and manufactured to meet strict quality and safety standards. There are, however, some installation and operation precautions which you should be particularly aware of.

1. Read instructions-All the safety and operating instructions should be read before the appliance is operated.
2. Retain instructions-The safety and operating instructions should be retained for future reference.
3. Heed Warnings-All warnings on the appliance and in the operating instructions should be adhered to.
4. Follow Instructions-All operating and use instructions should be followed.
5. Cleaning-Unplug this product from the wall outlet before cleaning. Do not use liquid cleaners or aerosol cleaners. Use a damp cloth for cleaning.
6. Attachments-Do not use attachments not recommended by the product manufacturer as they may cause hazards.
7. Water and Moisture-Do not use this product near water-for example, near a bath tub, wash bowl, kitchen sink, or laundry tub, in a wet basement, or near a swimming pool, and the like.
8. Accessories-Do not place this product on an unstable cart, stand, tripod, or table. The product may fall, causing serious injury to a child or adult, and serious damage to the appliance. Use only with a cart, stand, tripod, bracket, or table recommended by the manufacturer, or sold with product. Any mounting of the appliance should follow the manufacturer's instructions, and should use a mounting accessory recommended by the manufacturer.
9. Ventilation-Slots and openings in the cabinet are provided for ventilation and to ensure reliable operation of the product and to protect it from overheating, and these openings must not be blocked or covered. The openings should never be blocked by placing the product on a bed, sofa, rug, or other similar surface. This product should never be placed near or over a radiator or heat register. This product should not be placed in a built-in installation such as a bookcase or rack unless proper ventilation is provided or the manufacturer's instructions have been adhered to.
10. Power sources-This product should be operated only from the type of power source indicated on the marking label. If you are not sure of the type of power supply to your home, consult your appliance dealer or local power company.
11. Grounding or Polarization-This product is equipped with a polarized alternating-current line plug (a plug having one blade wider than the other). This plug will fit into the power outlet only one way. This is a safety feature. If you are unable to insert the plug fully into the outlet, try reversing the plug. If this should still fail to fit, contact your electrician to replace your obsolete outlet. Do not defeat the safety purpose of the polarized plug.
12. Power-Cord Protection-Power supply cords should be routed so that they are not likely to be walked on or pinched by items placed upon or against them, paying particular attention to cords at plugs, convenience receptacles, and the point where they exit from the appliance.
13. Protective Attachment Plug-The appliance is equipped with an attachment plug having overload protection. This is a safety feature. See Instruction Manual for replacement or resetting of protective device. If replacement of the plug is required, be sure the service technician has used a replacement plug specified by the manufacturer that has the same overload protection as the original plug.
14. Lightning-For added protection for this product during lightning storm, or when it is left unattended and unused for long periods of time, unplug it from the wall outlet. This will prevent damage to the product due to lightning and power-line surges.
15. Overloading-Do not overload wall outlets and extension cords as this can result in a risk of fire or electric shock.
16. Object and Liquid Entry-Never push objects of any kind into this product through openings as they may touch dangerous voltage points or short-out parts that could result in a fire or electric shock. Never spill liquid of any kind on the product.

Dimensions

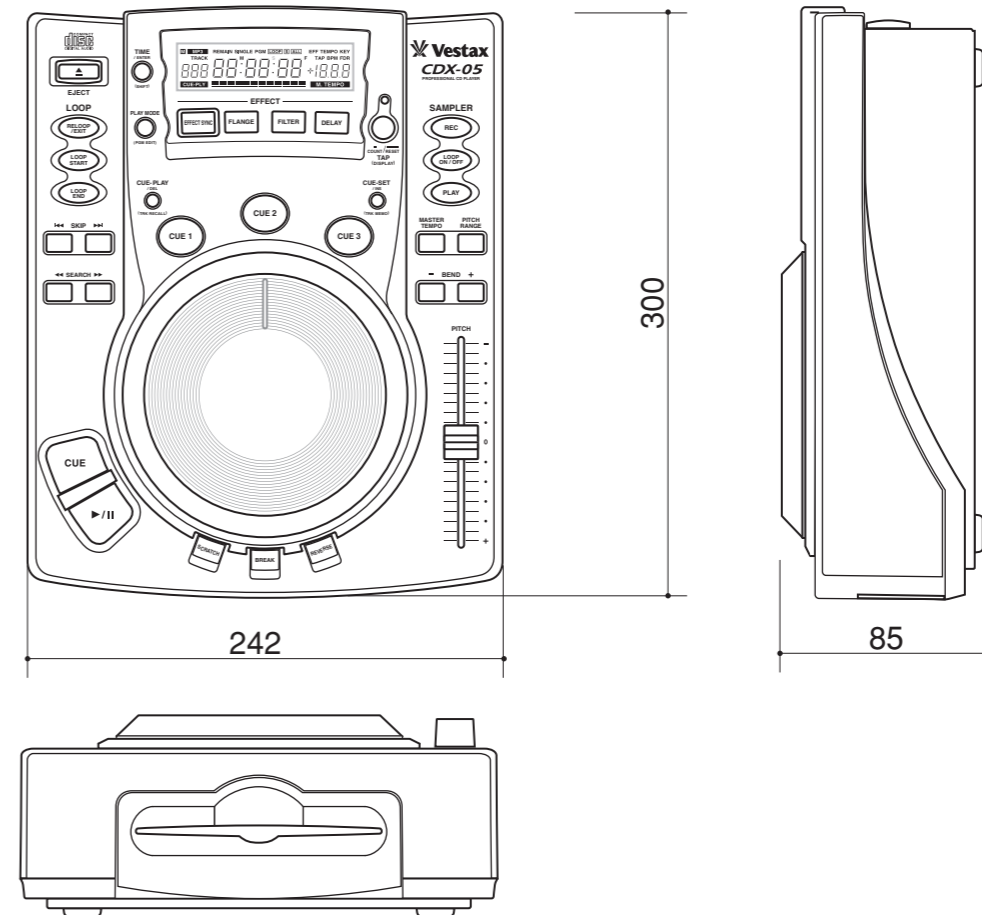

3-13. Backup Memory

Each time you turn off the power, the status of following features are stored into backup memory.

- Time mode
- Play mode
- CUE-PLAY on/off
- Brake on/off
- Brake Time
- TEMPO Range
- Preset Settings
- CUE mode
- Program
- Effect on/off
- Reverse Play on/off
- Master Tempo on/off

4. Specifications

Disc type: 8cm / 12cm CD, CD-DA/CD-R/CD-RW
Number of channels: 2-channel
Resolution: 16-bit
Sampling frequency: 44.1kHz
Analog output: RCA pin jack
Output impedance: <1kohm
Nominal output level: -10dBV(0.32V)
Maximum output level: +6dBV(2.0V)
Digital output: Coaxial
Format: IEC60958 Type II
Fader Start jack: ϕ 3.5 mini phone jack
TT-LINK jack: MIDI DIN

Voltage requirements
USA/Canada: 120V AC, 60Hz
UK/Europe: 230V AC, 50Hz
Power consumption: 11W
Peak inrush current: 0.9A
Applicable electromagnetic environment: E4
Dimensions (W x H x D mm)
Main unit: 242 x 300 x 85
Weight: 5.9kg

Error Messages

If any of the numbered error messages occur, try using another disc.
If the errors continue with a number of discs, turn the unit off, wait for a few seconds, and turn it on again.
If the errors still continue or other error occurs, contact your VESTAX distributor for repair.

- Err 01 TOC Read error - the disc's Table of Contents cannot be read within 20 seconds - try with another disc or remove and clean the existing disc before replacing it
- Err 02 GFS error ? GFS signal cannot be detected within five seconds - try with another disc or remove and clean the existing disc before replacing it
- Err 03 Focus error - after repeating the attempt eight times to focus, an error still occurs - try with another disc or remove and clean the existing disc before replacing it
- Err 04 Sub-Q error - the sub-Q code cannot be detected (twice within five seconds) - try with another disc
- Err 05 Loading error - the open or close operation cannot be completed, even after retries, or there is an internal error - make sure that there are no obstructions preventing the tray's operation
- Err 06 Sled error - an internal drive error - try turning the power off, waiting a few seconds, and turning it on again
- Err 07 Error in communication between decks - try turning the unit off, waiting a few seconds, and turning it on again
- Err 10 S-DRAM error - an internal S-DRAM error - try turning the power off, waiting a few seconds, and turning it on again

17. Servicing-Do not attempt to service product yourself as opening or removing covers may expose you to dangerous voltage or other hazards. Refer all servicing to qualified personnel.
18. Damage Requiring Service-Unplug this product from the wall outlet and refer servicing to qualified service personnel under the following conditions:
- a. When the power-supply cord or plug is damaged.
 - b. If liquid has been spilled or objects have fallen into the product.
 - c. If the product has been exposed to rain or water.
 - d. If the product does not operate normally by following the operating instructions. Adjust only those controls that are covered by the operating instructions as an improper adjustment of other controls may result in damage and will often require extensive work by a qualified technician to restore the product to its normal operation.
 - e. If the product has been dropped or cabinet has been damaged.
 - f. When the product exhibits a distinct change in performance-this indicates need for service.
19. Replacement Parts-When replacement parts are required, be sure the service technician has used replacement parts specified by the manufacturer or have the same characteristics as the original parts. Unauthorized substitutions may result in fire, electric shock or other hazards.
20. Safety Check-Upon completion of any service or repairs to product, ask the service technician to perform safety checks to determine that the product is in proper operating condition.
21. Carts and Stands-The appliance should be used only with a cart stand that is recommended by manufacturer.
22. An appliance and cart combination should be moved with care. Quick stops, excessive force, and uneven surfaces may cause the appliance and cart combination to overturn.



FEATURES

- It is the single CD player for DJ which corresponded to the function and the performance for which CD player for DJ is required, and adhered to tone quality.
- By passing through the electronic parts selected carefully and an original circuit, a digital sound peculiar to CD is made to the tone quality which creates the warmth of analog. Thereby, the mixture condition of the sound when mixing with the sound of an analog turntable changes at the time of DJ play.
- Three kinds of effects(flanger, a delay and filter) are built in this unit, and it can be synchronized with BPM which automatic-detected or set manual up (it is to one line that it can be used simultaneously).
- It corresponds also to reproduction of an MP3 file in addition to the usual CD data. It is possible to reproduce the MP3 file recorded on CD-R/RW. (However, MP3 reproduction has restriction in functions, such as a CUE point and loop reproduction)
- Each music is distinguished from the number of time of the whole CD, or the length of music, and the track memory function to make a setup memorize in a main part at the time of reproduction of a maximum of 100 tracks is carried. The work of teaching a CUE point LOOP point, a BPM value, etc. beforehand can also be done.
- The JOG wheel with a touch switch convenient for a search and scratch operation is adopted as a JOG wheel. Thereby, operation becomes possible with the operation feeling of an analog turntable. Moreover, it can be operated by connecting with TASCAM TT-M1 using VESTAX turntable PDX-2000 series instead of a JOG wheel.

BEFORE USE

Using CDs.

A conventional CD consists of two (2) sides. Typically one side bears a label stating the name of the CD and artist whilst the front side, rainbow like in its color, contains the information that makes this technology work. There are approximately six (6) million data items stored on any one given CD front surface. Please make sure to load the CD into the playing mechanism correctly, so that the front side (rainbow) is unable to be seen once the lid is closed.

Unlike conventional analog turntables, CD technology uses a fine laser beam instead of a stylus to read the contents of the disc. As a result of there being little physical contact, a CD will take infinitely longer to degrade. Repeated use of a CD, even playing over the same track again and again will likely have very little effect on the audible quality of the discs data.

However, the front surface of a CD is brittle and may be scratched or damaged if you are careless in its handling. Thus, please take care to load you CDs correctly and ensure that you store them in a safe place. Furthermore, avoid leaving CDs in direct sunlight or in close proximity to a heating device or hot object, in the rain or in water, or on surfaces that have excessive moisture or surface dirt/grime. Also take care when cleaning any CD by using a recommended or special purpose cleaning cloth, cleaning spray or product and always wipe in the direction illustrated below.

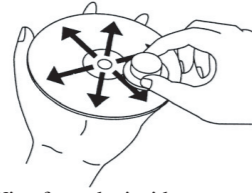

● Wipe from the inside out.

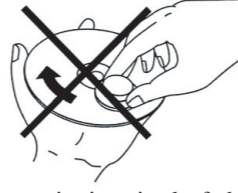

● Do not wipe in a circular fashion.

● Never use record cleaner designed for conventional analog disks, this will degrade the CD disc surface.

■ Always store disc properly in the case.

Warning

- Please do not inhibit access to this unit's main switch by operating it in a confined area.
- Do not expose to water, moist environments or operate this device in an area likely to be effected by liquid spillage or dripping.

Playing the MP3 file

1. Insert the CD-ROM which including the MP3 files.
2. Pressing the SKIP key selects the MP3 file.
3. Press the PLAY/PAUSE key.

Pressing and holding the SHIFT key and then pressing the SKIP key to skips the directory.

NOTE

● Since the CDX-05 does not support the text display, the text information which are included in the ID tag are not displayed. File number is shown in the TRACK number area and directory number is shown in the parameter display. When parameter display shows the directory number, DIR indicator will light.

3-12. Preset menu

Pressing and holding the SHIFT key and then using the Jog wheel selects the preset menu.

Set the parameter with the Jog wheel.

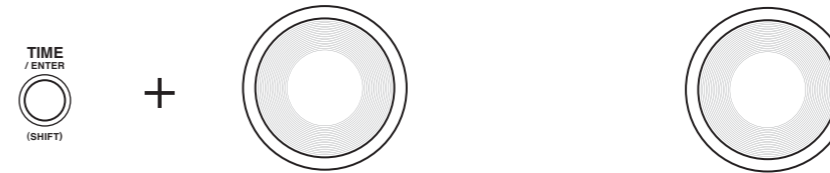

Select the preset menu then press the ENTER key, the LCD shows the preset menu and its parameter.

Pressing the ENTER key confirms the new parameter.



Pressing any other key exits the preset operation.

Preset	Number Item	Parameter (*: default)	Function
01 CD FLT	CD FILTER	OFF, 0n*	Turns the "CD filter" on or off
02 T. PL AY	TIMER start	OFF*, 0n	Turns the "gpower on play" on or off
03 dir ECt	DIRECT mode	OFF*, 0n	When direct mode is set to on, disc can be ejected when disc is played, and when insert the disc, playback is started automatically.
04 rE Ad	TOC READ mode	nor*, RUt	Selects the TOC read mode. nor : Uses the previous servo value. RUt : Adjust the servo value every time.
05 FA dEr	FADER Start mode	Ed*, SRn, ERn	Select the FADER start mode. Ed : Disc playback is started and stopped with the fader. SRn : Controls the playback of the sampler. ERn : Controls a combination of disc and sampler playback.
07 F Pr E	Factory Preset	-SUr E-	Initialize the preset menu.
08 AL Lc Lr	Memory All Clear	-SUr E-	Clear the all memorized data.

3. Press CUE-SET/INS key.



4. Select desired track with track skip keys.

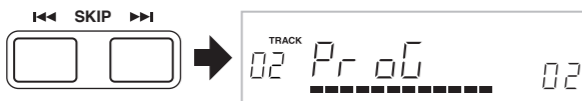

5. Repeat 2-4.

6. Exit the program edit mode by pressing and holding the SHIFT key and then pressing the PLAY MODE/PGM EDIT key.



Delete program

1. Enter the program edit mode by pressing and holding the SHIFT key and then pressing the PLAY MODE/PGM EDIT key.



2. Program number is shown in the parameter display. Select desired program number that you want to delete the program with the Jog wheel.

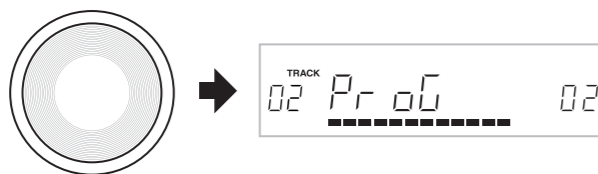

3. Press CUE-PLAY/DEL key.

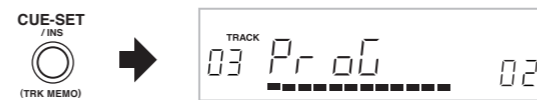

4. Repeat 2-3.

5. Exit the program edit mode by pressing and holding the SHIFT key and then pressing the PLAY MODE/PGM EDIT key.



3-11. MP3 file playback

The CDX-05 can play the MP3 file which is recorded as following specific format.

Disc format: ISO9660 Level 1
 Number of directories: up to 254
 Number of files: up to 255
 File format: MPEG 1 audio layer 3
 Bit rate: 32kbps to 190kbps,
 Constant Bit Rate
 Sampling frequency: 44.1KHz, Stereo
 File extension: mp3, Mp3, mP3, MP3

NOTE

- Backward direction of the scratching can be performed up to 7 seconds.

NOTE

- If the disc is recorded with multi session, the CDX-05 can read the files in first session area only.
- Variable bit rate (VBR) format is not supported.
- MP3 playback function does not support following functions.

- CUE and CUE 1-3
- Loop play
- Search
- Reverse play
- Track memory
- Total remain time display
- Remain time display
- Time address bar display

1. Functions and Controls

1-1. Top Panel

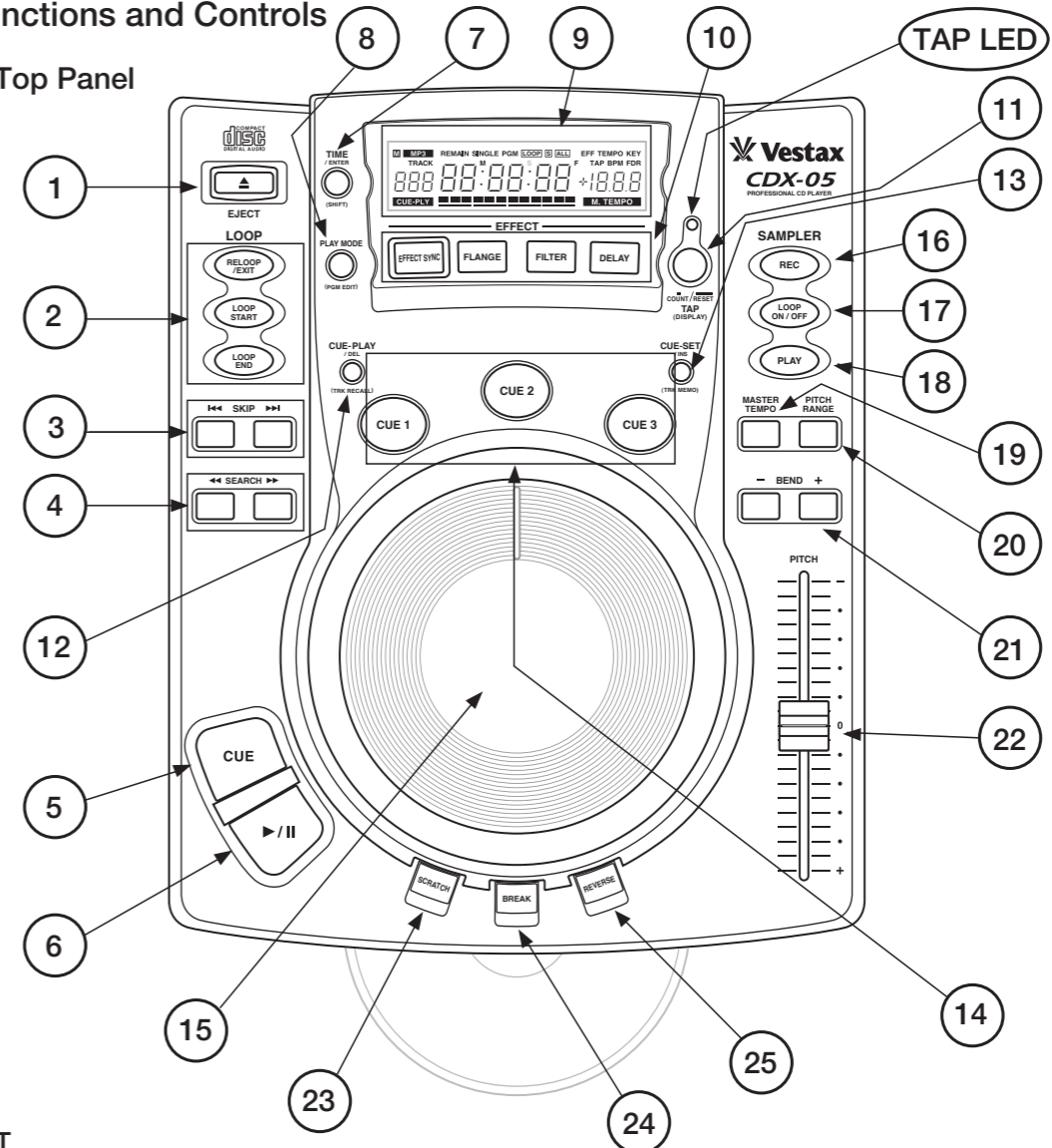

1. EJECT

A disc is ejected.

NOTE

These keys cannot be used when direct mode (Preset menu: page 23) is off and a disc is being played back.

2. RELOOP/EXIT, LOOP START, LOOP END

Sets the loop points, or engages or disengages the loop playing. (P.12)

3. Track Skip keys

Use these to perform track searches.

4. SEARCH key

Use these to perform track searches.

5. CUE

Locates to the cue point, then pauses.

Stutter play can be performed with this key. (P.11)
 Selects the CUE key's operation mode. (P.11)

6. PLAY/PAUSE

Changes the playback mode between playback and pause.

The light stays on solid in playback mode and flashes in pause mode

7. TIME / ENTER / SHIFT

Selects the time display mode, either remain, elapsed or total remain.

REMAIN :REMAIN indicator in the LCD will light

ELAPSED :Elapsed time will show in the numerical portion in display, but no additional indicator will light.

TOTAL REMAIN:The track number display area shows the number of tracks of inserted disc, however, for 5 seconds in the end of track, the current track number flashes and for 5 seconds in the beginning of the track, the current track number lights.

Another function of this key is the modifier key (SHIFT function). Holding SHIFT while pressing another key performs the following functions;

SHIFT + PLAY MODE: Program Edit

SHIFT + CUE-PLAY: Track memory Recall

SHIFT + CUE-SET: Track memory

SHIFT + TAP: Parameter display select

SHIFT + JOG: Preset

SHIFT + LOOP END: Loop end point edit

SHIFT + CUE: Select the CUE key's operation

8. PLAY MODE / PGM EDIT

Selects the play mode, either all play, single play (1 track play), programmed play, all repeat play, single repeat play or program repeat play.

All play : No indication in the LCD

Single play : "SINGLE" indicator in the LCD will light

Programmed play : "PGM" indicator in the LCD will light

All repeat play : "ALL" and "LOOP" indicators in the LCD will light

Single repeat play : "SINGLE", "S" and "LOOP" indicators in the LCD will light

Programmed repeat play: "PGM" and "LOOP" indicators in the LCD will light

Pressing and holding the TIME/ENTER/SHIFT key while pressing the PLAY MODE key, enters program edit mode. (P.20)

9. LCD

Displays visual feedback for CDX-05 functions

10. EFFECT SYNC / FLANGE / FILTER / DELAY

EFFECT SYNC : Turns on and off synchronization of the effect time with the BPM.(P.16)

FLANGE : Turns the Flanger effect on and off.(P.17)

FILTER : Turns the Filter effect on and off.(P.17)

DELAY : Turns the Echo effect on and off.(P.17)

11. TAP / DISPLAY

Sets the tempo in BPM by tapping this key. When you press this key, the parameter counter mode momentarily changes to TAP BPM display mode. (P.14)

Pressing and holding the SHIFT key while pressing this key selects the parameter display mode.

TEMPO -> KEY -> TAP -> BPM -> (FDR) ->

12. CUE-PLAY / TRK RECALL / DEL

Turns the CUE-PLY mode on and off.

Recalls the track memory data.

Deletes the current selected song from the program list. (P.11)

13. CUE-SET / TRK MEMO / INS

Set the cue points with CUE 1-3.

Memorizes the track memory data.

Deletes the current selected song from the program list. (P.11)

14. CUE 1-3

Depending on the setting, these keys locate to cue points, flash start (cue-ply) from cue points, or stutter play from cue points. (P.11)

15. JOG Wheel

The following functions can be controlled by the Jog wheel.

- Search
- Pitch Bend
- Scratch
- Brake time
- Key control
- Preset menu
- Effect parameters
- Sampler tempo/level
- Program edit
- Track memory number select

16. REC

If this key is pushed once, it will be in a sampling standby state (blink), and a sampling will be started (lighting) if it pushes on the next. A sampling will be stopped if it pushes again (lights out).(p.18) Sampling time is for 8 seconds at the maximum.

2. Program number is shown in the parameter display. Select the desired track with the track skip keys.



3. Go to next program number by pressing the ENTER key or using the Jog wheel.

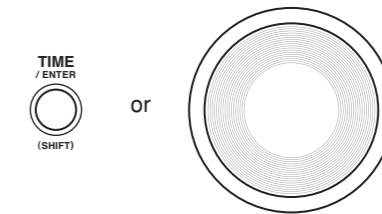

4. Repeat 2-3.

5. Exit the program edit mode by pressing and holding the SHIFT key then pressing the PLAY MODE/PGM EDIT key.



Edit program

1. Enter the program edit mode by pressing and holding the SHIFT key and then press the PLAY MODE/PGM EDIT key.



2. Program number is shown in the parameter display. Select the desired program number with the Jog wheel.



3. Select desired track with track skip keys.



4. Repeat 2-3.

5. Exit the program edit mode by pressing and holding the SHIFT key then pressing the PLAY MODE/PGM EDIT key.



Insert program

1. Enter the program edit mode by pressing and holding the SHIFT key and then pressing the PLAY MODE/PGM EDIT key.

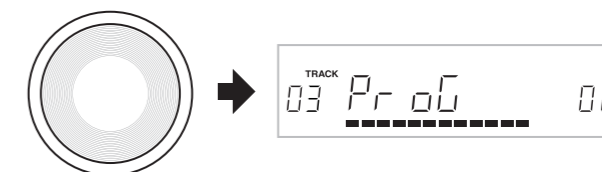

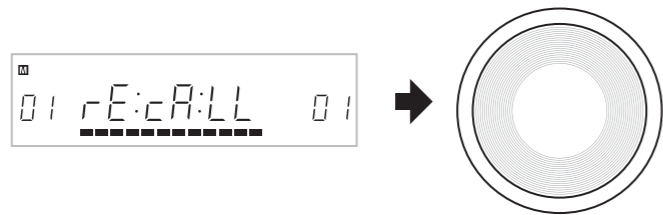

2. When track memory number is shown in the LCD, pressing the ENTER key recalls the track from the track memory number.

NOTE

Cue and loop points can be memorized and/or recalled. However, just after the recall operation, seamless start from the cue or loop points can't be performed because there are no data in the RAM buffer just after the recall operation. Once playing from cue points (CUE 1-3) and/or loop start point for a few second, flash start and/or seamless looping can be performed.

3-8. Fader Start

Connect the FADER START jack on the rear panel of the main unit and fader start jack on the external device which supports the fader start function (i.e.X-9, X-17, X-15, XS-3, etc...) with Fader Start Cable which is supplied to perform the fader start/back cue performance with the external device. Audio signal should be connected to the external device as well.

3-9. TT-M1 (TASCAM) Play

By connecting with TT-M1 (TASCAM) set to the analog turntable, this unit can be operated on an analog turntable instead of a JOG wheel.

NOTE

Please turn off the scratch mode of the CDX-05 when using the TT-M1. The machine might not function stably if it is turned on.

Setting

1. The connection cable of TT-M1 is connected to the TT-LINK terminal of this unit, and TT-M1 is turned on.
2. The PLAY key is pushed, pushing the SHIFT key and adjustment with this unit is performed.

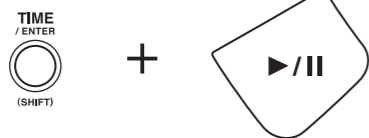

NOTE

In case you use TT-M1, please do not carry out use, without surely adjusting. If it is used without adjusting, there is a possibility that it may not work normally.

3-10. Programmed Play

The CDX-05 features up to 30 tracks of program play function. Program itself is maintained even if power is turned off, and if CD is not ejected, program list will be backed up.

NOTE

- If the disc is ejected, program will be erased.
- Once one of the CUE 1-3 key is pressed, programmed play will be cancelled.

Create the program

1. Enter the program edit mode by pressing and holding the SHIFT key and press the PLAY MODE/PGM EDIT key.



17. LOOP ON/OFF

Turn the sampler loop playing on and off. (P.18)

18. PLAY

Sampler is playedback while pushing this key. (p.18) If this key is detached, sampler will be stopped. If this key is pushed during sampler loop reproduction, reproduction will be started from the beginning of sampling data.

19. MASTER TEMPO

Turns the MASTER TEMPO function on and off. (P.15)

Pressing and holding this key then moving the Jog wheel sets the key control value. (P.12)

20. PITCH RANGE

Selects the pitch range, either +/-6, 10, 50, 100 or 0% . (P.13)

21. BEND +/-

Use these keys to perform pitch bending. (P.14)

22. PITCH fader

Changes the playback tempo. (P.14)

23. SCRATCH

Turns the scratch play mode on and off. When scratch play mode is on, this key lights and scratch can be performed by Jog wheel. (P.15)

24. BRAKE

Turns the brake function on and off and sets the brake time using the Jog wheel. (P.16)

25. REVERSE

Changes the playback direction between forward and backward. (P.17)

1-2. LCD

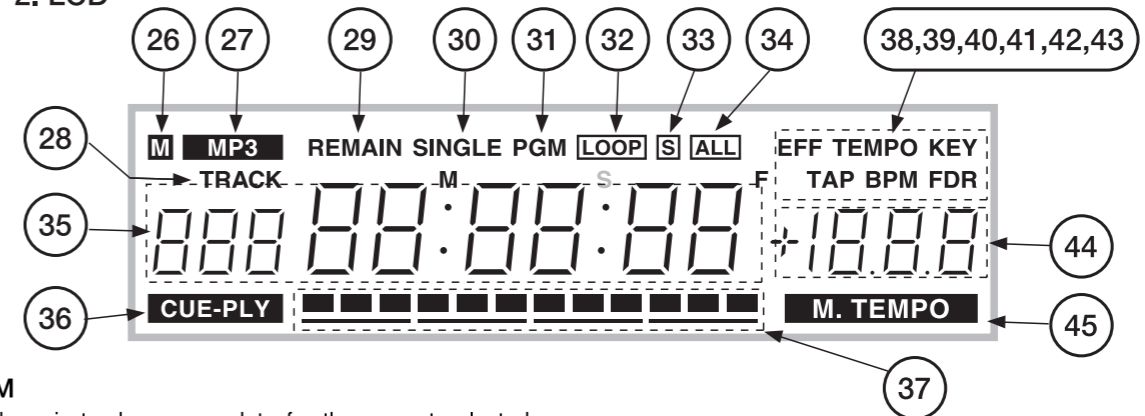

26. M

If there is track memory data for the current selected track in the memory, this indicator lights.

27. MP3

When a MP3 CD-ROM disc is inserted, this indicator lights.

28. TRACK

29. REMAIN

When the time mode is set to remain time mode, this indicator lights.

30. SINGLE

When the play mode is set to single play, this indicator lights.

31. PGM

When the play mode is set to programmed play, this indicator lights.

32. LOOP

Lights when loop and repeat play are engaged.

33. S

Lights when loop mode is set to single repeat.

34. ALL

Lights when loop mode is set to all repeat.

35. Time display

This section is used to show track number, time values or messages.

36. CUE-PLAY

When flash start is activated, this indicator lights. Flash start mode is off by default, or the last setting of flash start will be retained. If you set it to ON then turn the power off, when power is turned back on, flash start will be ON.

37. Time Address Bar

Shows the current play position relative to the current track.

38. EFF

Lights when parameter display shows the effect parameter.

39. TEMPO

Lights when parameter display shows the TEMPO value.

40. KEY

Lights when parameter display shows the key value.
Lights when key value is set to other than 0%.

41. TAP

Lights when parameter display shows the tap value.

42. BPM

Lights when parameter display shows the auto BPM value.

43. FDR

When a MP3 CD-ROM disc is inserted, this indicator lights and parameter display shows the current selected directory number.

44. Parameter display

Displays the various parameters.

45. M.TEMPO

Lights when master tempo function is activated.

1-3. REAR PANEL

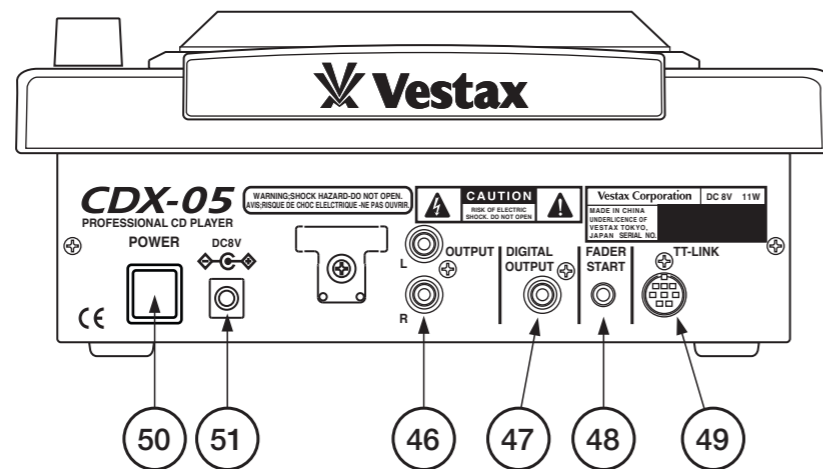

46. OUTPUT jack (RCA)

RCA connectors providing line level output signal.

47. DIGITAL OUTPUT jack (COAXIAL)

Coaxial connectors provide digital output signal. These connectors can output the 44.1KHz digital signals constantly even if pitch control is activated.

48. FADER START jack (MINI jack)

The CDX-05 can be controlled using the external Fader start command through this jack. Connect the mixer, which supports the fader start function with appropriate cable as well as audio signal. (P.20) (TIP: Start, GND: back cue)

49. TT-LINK jack (MINI DIN 6P)

Connect the optional scratch controller TT-M1 (TASCAM).

50. POWER switch

Turns the power on and off.

51. DC POWER jack

Connect the VESTAX DC-8, AC adaptor.

Sampler output level

While pushing the PLAY key then using the Jog wheel adjusts the sampler output level. The sampler output level can be set from 0 (mute) to 100 (default level).

SAMPLER

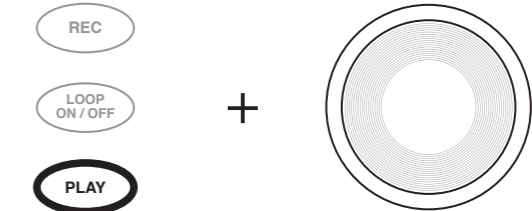

3-7. Track Memory / Recall

The CDX-05 can memorize the various playback settings of current selected tracks up to 100 tracks of memory.

Track Memory

1. Enter the track memory mode by pressing and holding the SHIFT key then pressing the TRK MEM key.



2. LCD shows the lowest empty memory number.



3. Use the Jog wheel to change the memory number if necessary.

4. Press the ENTER key. At this time, if there is stored memory in the selected memory number, indication is displayed *-SURE-* in the LCD.

Pressing the ENTER key overwrites the current track data. Pressing any other key cancels the memory operation.



Memory data

- DISC ID
- CUE 1-3 points
- LOOP mode
- MASTER TEMPO On/Off
- Brake On/Off
- Time mode
- CUE point
- LOOP A/B points
- Play mode
- TAP value
- Brake Time

NOTE

Sampling points for the MP3 file cannot be memorized

Recal

1. Enter the recall mode by pressing and holding the SHIFT key and pressing the TRK RECALL key. If there is a track memory data for the current selected track, its memory number is shown in the LCD.



2. When track memory number is shown in the LCD, pressing the ENTER key recalls the track memory data.



The CDX-05 can recall the track (song) from the track memory data.

1. Enter the recall mode by pressing and holding the SHIFT key then pressing the TRK RECALL key. Using the Jog wheel to select the desired track memory number.



3-6. Sampler

The CDX-05 includes eight seconds sampler on each player.

Sampling

NOTE

- When you sample, please check that the sampler has stopped.
- Elimination of sampling data cannot be performed. Sampler can always overwrite.

1. Push the REC key once during play or a stop. The REC key blinks at this time and it will be in a REC standby state.

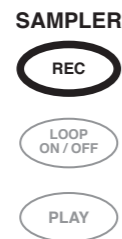

After pushing the REC key, if 8 seconds of the maximum recording time passes, sampling will be stopped automatically.

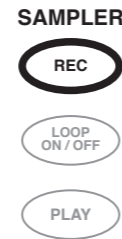

2. Push the REC key again during play or stop, recording will begin and the REC key will light up.

3. If the REC key is again pushed during play or a stop, a sampling will be ended and a deed REC key will switch off blink 3 times.

Sampler Play

After sampling, push PLAY key, and Sampled track will start. If the PLAY key is de-tached, Sampler will stop.

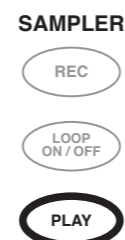

Sampler Loop

Press the LOOP key then push the LOOP key to turn the sampler loop play on and off. When sampler loop play is activated, LOOP LED will light.



Sampler Pitch Control

While pushing the Loop key the Jog wheel changes the play back pitch of the sampler. The pitch control range is +/-32% in 0.1% steps.

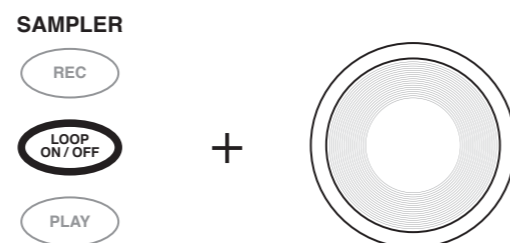

2. Playback operation

2-1. CUE

The CDX-05 can memorize the play start point as a cue point. If the cue point is memorized, pressing the CUE key locates the unit to the cue point.

To memorize the CUE point

There are two ways to store the cue point.

Pressing and holding the SHIFT key then pressing CUE selects the method for the CUE key's operation.

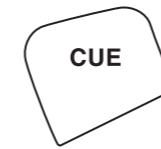

CUE

Pressing the CUE key when unit is paused stores the current point as the cue point.

PLY

Last play start point is stored as the CUE point.

Stutter play with the CUE key

When unit is paused at the cue point, the unit will play when this key is pressed, and enter pause mode when CUE is released.

If the PLAY key is pressed during CUE playback, the unit will go into normal play mode.

2-2. CUE 1-3

The CDX-05 can have another three cue points stored with the CUE 1-3 keys.

To memorize the CUE 1-3 points

1. Find the desired point.
2. Press the SET key. The parameter display shows .
3. Press the desired CUE key.



When the CUE key has the stored point, the CUE key lights. The stored cue point cannot be erased but can be overwritten.

NOTE

- When the unit is paused and the CUE-PLY indicator in the LCD lights, pressing the SET key then pressing the CUE 1-3 key starts the unit automatically.
- When the unit is paused and the CUE-PLY indicator in the LCD doesn't light, pressing the SET key then pressing the CUE 1-3 key flashes the pressed CUE 1-3 key three times then lights.
- For three seconds after storing the cue point, you cannot store another cue point.

Stutter play with the CUE 1-3 keys

When the unit is paused at the cue 1-3 point, the unit will play when the appropriate CUE 1-3 key is pressed, and enter pause mode when CUE 1-3 is released.

If the PLAY key is pressed during CUE playback, the unit will go into normal play mode.

2-3. CUE-PLAY

The CDX-05 has a flash start function that can be used with the CUE 1-3 keys. When the flash start function is activated (when the CUE-PLY indicator in the LCD lights), pressing the CUE 1-3 key enables flash start.



NOTE

When the CUE-PLY indicator in the LCD doesn't light, the unit is back in cue mode. In this mode, pressing the CUE 1-3 key locates the stored cue point then the unit pauses.

2-4. A-B Looping

To store the LOOP points

1. Press the LOOP START key when playing or pausing. The LOOP START key will light and the LOOP END key will start flashing.

LOOP



LOOP



2. Press the LOOP END key when playing or pausing. LOOP START and LOOP END keys will light. If the loop end point is set when the unit is playing, the CDX-05 starts loop playback seamlessly. If the loop end point is set when the unit is paused, the CDX-05 goes to the loop start point then pauses.

NOTE

- When you register loop point, please check that it is not under loop reproduction now. A setup of a loop point cannot be performed during loop reproduction.
- Loop point elimination cannot be performed. A loop point can always be overwritten.
- Please register a loop point in the same track. It does not correspond to loop reproduction over a track.
- A LOOP END point can be set only to back from a LOOP START point.
- Reverse reproduction of a loop cannot be performed.
- Both loop start and end points can set to within a track.

Disengage loop play

When loop play is engaged, pressing the RE-LOOP/EXIT key disengages loop play. In this case, the unit continues playback and RELOOP/EXIT key light goes off, but the loop points are not erased.

When loop play is engaged, locating to the out point of a loop section disengages loop play (i.e. pressing the CUE key, etc...). The LOOP key goes off, but the loop points are not erased.

LOOP



Effect level setting

When an effect is activated, pressing and holding the SHIFT key then pressing the activated effect key enters the effect level setting mode. In this mode, using the Jog wheel can change the effect level. The effect level parameter is shown in the parameter display.

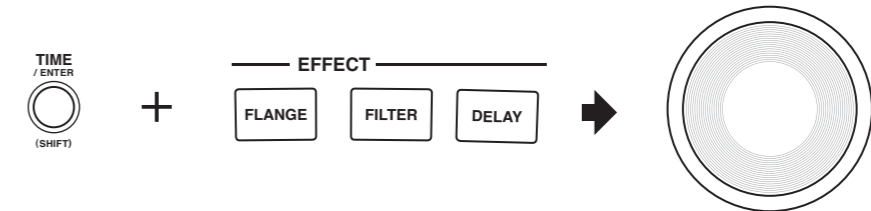

FLANGER

Pressing the FLANGE key activates the Flanger effect.
 Effect time: 10msec - 16sec (default: 500msec)
 Effect beat: 32, 16, 8, 4, 2, 1, 1/2 (default: 1)
 Effect level: 0 - 100 (default: 75)

FILTER

Pressing the FILTER key activates the Low pass filter effect.
 Effect time: 10msec - 16sec (default: 2sec)
 Effect beat: 32, 16, 8, 4, 2, 1, 1/2 (default: 4)
 Effect level: 0 - 100 (default: 75)

DELAY

Pressing the DELAY key activates the Delay effect.
 Effect time: 1msec - 3,500msec (default: 500msec)
 Effect beat: 2, 1, 3/4, 1/2, 1/4 (default: 1)
 Effect level: 0 - 100 (default: 75)

Filter effect has two operation modes, manual mode and auto mode. In manual mode, filter frequency can be controlled with the Jog wheel. In auto mode, filter frequency is moved automatically followed by BPM and effect beat parameter.

Pressing and holding the FILTER key more than 1.5 seconds changes the filter effect mode.

NOTE

When filter effect mode is set to manual mode, you can move the filter frequency using with the Jog wheel even if the scratch function.

3-5. Reverse play

The CDX-05 features the reverse play function. Pressing the REVERSE key changes playback direction. When playback is reversed, the REVERSE key will light.



NOTE

- More than 3 seconds after pausing, reverse play cannot be performed.
- In the reverse play mode, CUE PLAY, creating the loop point, and auto cue functions do not work.
- Reverse play of loop cannot be performed. If the RELOOP key is pushed during reverse play, reverse will be canceled and it will usually become loop play.

3-3. Brake

Brake function simulates the braking audio just like turning off the analog turntable. Pressing the BRAKE key turns the brake function on and off. When brake function is activated, BRAKE key lights.



Set the brake time

Pressing and holding the BRAKE key then using the Jog wheel adjusts the brake time. Brake time can be set to 0.1 to 5 seconds in 0.1 sec. steps.

Pressing the PLAY/PAUSE key while unit is playing performs the braking.

Pressing the PLAY/PAUSE key during the braking starts the music again with current tempo.

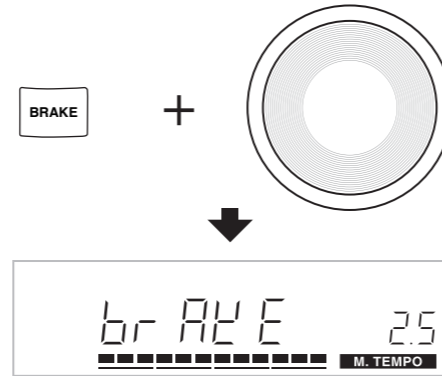

3-4. Effects

The CDX-05 includes three effects, Flanger, Delay, and Filter. One effect can be activated at the same time.

Pressing one of the effect keys can activate the effect.

Pressing the FX SYNC key synchronize the effect time with the BPM.

Pressing and holding the SHIFT key then pressing one of effect key can adjust the effect level with the Jog wheel.

Effect time setting

When an effect is activated, using the Jog wheel can adjust the effect time. The effect time parameter is shown in the parameter display.

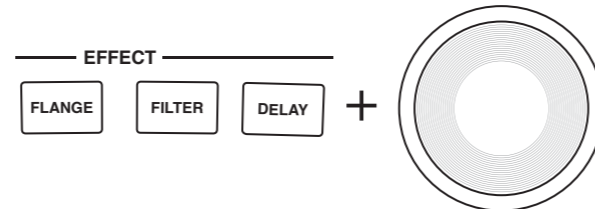

NOTE

When the scratch function turns on, the effect time cannot be controlled with the Jog wheel.

Synchronizing the effect time with the BPM

When an effect is activated and FX SYNC key is turned on (FX SYNC key lights), using the Jog wheel can change the effect beat synchronized with the BPM. The effect beat parameter is shown in the parameter display.

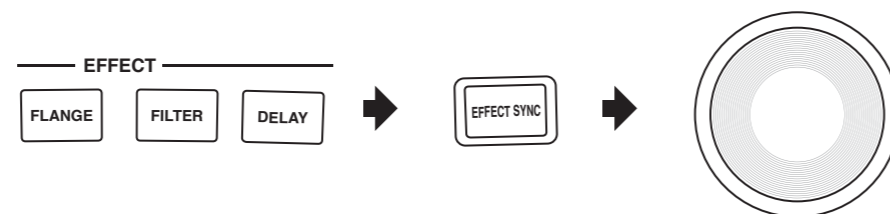

NOTE

When scratch function turns on, the effect beat cannot be controlled with the Jog wheel.

Re-looping

When loop play is disengaged and loop points are already stored, pressing the RELOOP/EXIT key starts reloop playback and the RELOOP/EXIT key lights.



Reproduction from a LOOP START point

If the LOOP START key is pushed during loop reproduction, reproduction will be started from a loop start point.



Changing the LOOP end point

Pressing the LOOP END key when the loop is playing changes the loop end point.



Pressing and holding the SHIFT key then pressing the LOOP END key edits the loop end point using the Jog wheel. Pressing the LOOP END key overwrites the new loop end point and exits the edit mode.

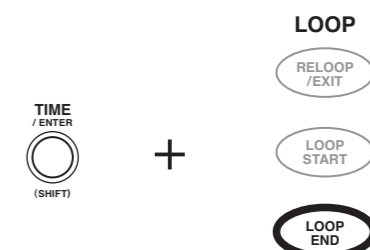

NOTE

The Loop end point can be moved before the current end point only.

2-5. Adjusting the pitch

Pitch range

The CDX-05 features +/-6, 10, 50, 100, and 0% of tempo control range. Pressing the PITCH RANGE key changes the pitch control range. The Parameter display shows the selected pitch/key range momentarily. If 0% is selected, the parameter display shows .



PITCH fader

The PITCH fader controls playback tempo. Tempo changes are displayed in the LCD.

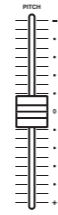

Auto BPM and TAP key

The CDX-05 features automatic BPM count function and TAP mode BPM count function. When parameter display mode is set to BPM, the BPM is counted automatically and displayed in the parameter display.

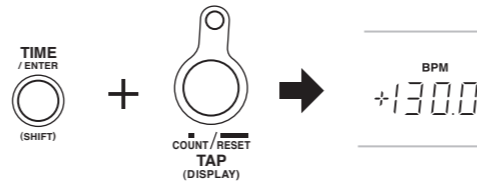

Pressing the TAP key repeatedly counts the song tempo in BPM manually. Tapped BPM is shown in the LCD parameter display and the TAP LED blinks in tempo. This BPM affects the TEMPO slider moving. If the TEMPO slider is moved, the BPM will be changed automatically.



Pressing and holding the TAP key for more than 1.5 seconds erases the tapped BPM value. Pressing and holding the TAP key then moving the Jog wheel (within 1.5 seconds) adjusts the BPM manually.

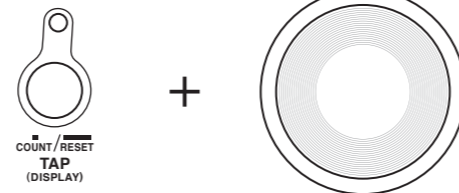

NOTE

BPM is also used for the effect time or beat parameter (P.16). When you set the BPM using with the TAP key, tapped BPM will be used for the effect time or beat

2-6. Pitch Bending

When playing back a disc, pressing the BEND + or - key, or using the Jog wheel can change playback tempo momentary. Pressing the + key or moving the Jog wheel clockwise increases the playback speed and returns to original speed when release this key or stop the Jog wheel moving. Pressing the - key or moving the Jog wheel counterclockwise decreases the playback speed and returns to original speed when release this key or stop the Jog wheel moving.

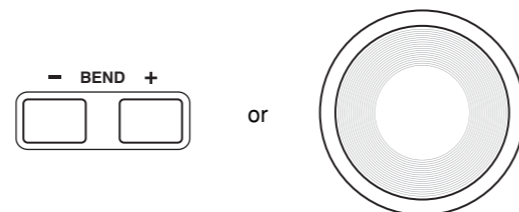

NOTE

- When SCRATCH key, or a effect key is not lit, the Jog wheel works for pitch bend function.
- The maximum pitch bend range is 10%.
- When MASTER TEMPO function is activated, playback key is fixed.

2-7. MASTER TEMPO

When tempo range is set to +/-6 or 10%, pressing the MASTER TEMPO key turns the master tempo function on and off. When master tempo function is turned on, tempo control does not affect the playback key. When the master tempo function is turned on, M. TEMPO indicator in the LCD lights. If tempo range is set to +/-50% or 100%, the key original function does not work. When the master tempo function is turned on, parameter display shows " - - - " in the KEY mode.



3. More advanced operation

3-1. Key control

The CDX-05 features up to +/-10% key control. Key control range is determined with tempo range setting. When tempo control range is set to 0%, or 100%, the key control function does not work. Pressing and holding the MASTER TEMPO key then moving the Jog wheel sets the key control value. Note that the key value shows a total of the value together with any changes made by using the slider.

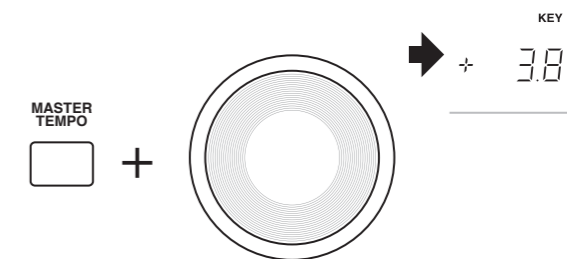

NOTE

- When the master tempo function is activated, the key control function does not work.
- The key control will return to 0% if you push the JOG wheel while operating.

3-2. Scratching

When the SCRATCH key is activated, scratching can be performed with the Jog wheel.

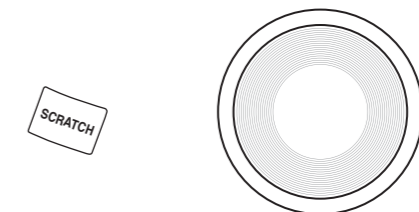

NOTE

- For 3 seconds after the CUE-PLY or cuing with CUE 1-3 key, or cuing with CUE key, backward direction of scratching cannot be performed
- Backward direction of the scratching can be performed up to 7 seconds.
- When filter effect is activated with manual mode, scratch function cannot be performed with the Jog wheel (P.17).